

2,50mm / 5,00mm / 7,50mm pitch connector
for 90° board-to-board connections.

Compatible with ITT Cannon G09 connectors.

Ultra low profile with only 1.80mm above board.

Used in consumer as well as industrial applications.

Any pincount available between 1 and 27.

Plastic can be easily broken to desired size.

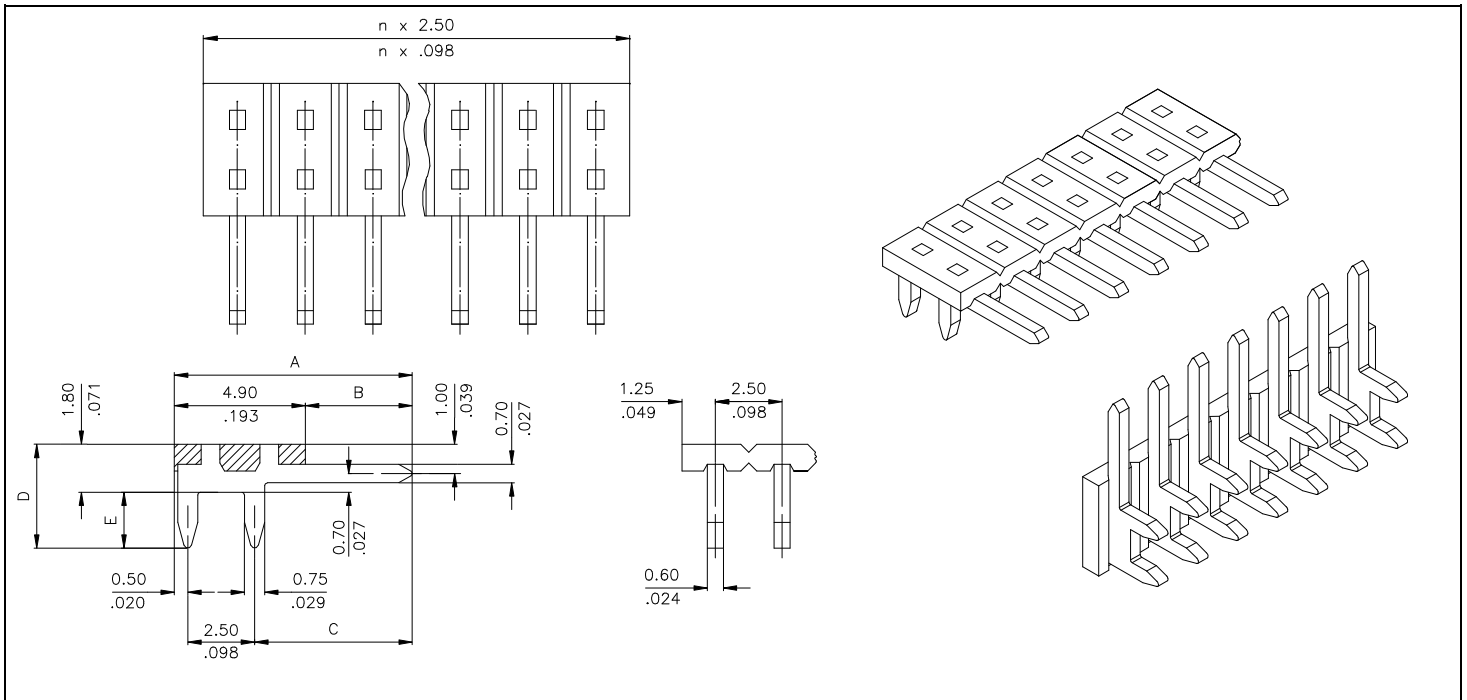
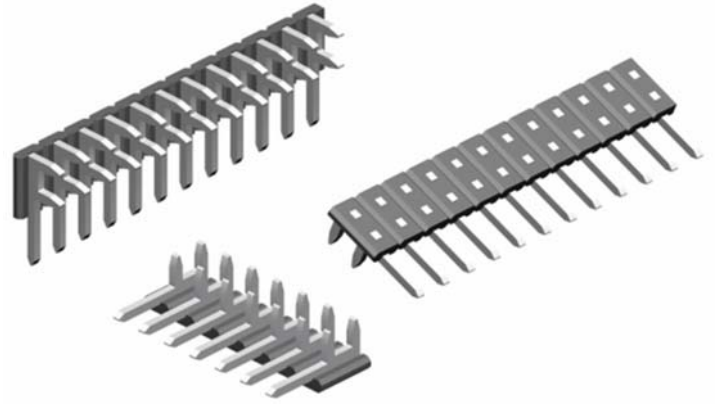

Specifications

Pitch	2,50 / 5,00 / 7,50mm	Insulation resistance	5 x 10 ⁹ MΩ
Contact material	CuZn	Breakdown voltage	600 V AC
Insulator	high temp plastic UL 94 V-0	Contact resistance	<10 mΩ
Operating temperature	-55° C to +125° C	Current rating	3 A max., 250V

How to order

PCB - xxx - Rxxx - 99 / x

Series	Nbr of contacts 001 to 027	Terminal style					Plating - 99 = tin (leadfree)	Pitch 3 = 2,5mm 4 = 5,0mm 5 = 7,5mm
		Dim "A"	Dim "B"	Dim "C"	Dim "D"	Dim "E"		
061		8,9mm	4,0mm	5,9mm	3,9mm	2,1mm		
153		11,4mm	6,5mm	8,4mm	3,9mm	2,1mm		
154		11,4mm	6,5mm	8,4mm	5,0mm	3,2mm		