

# Probe Pin Solderless Compression Test Socket

For BGA / Bumped chip / WLCSP / eMMC Package

0.80 mm pitch (from 0.80 mm to 0.99 mm)

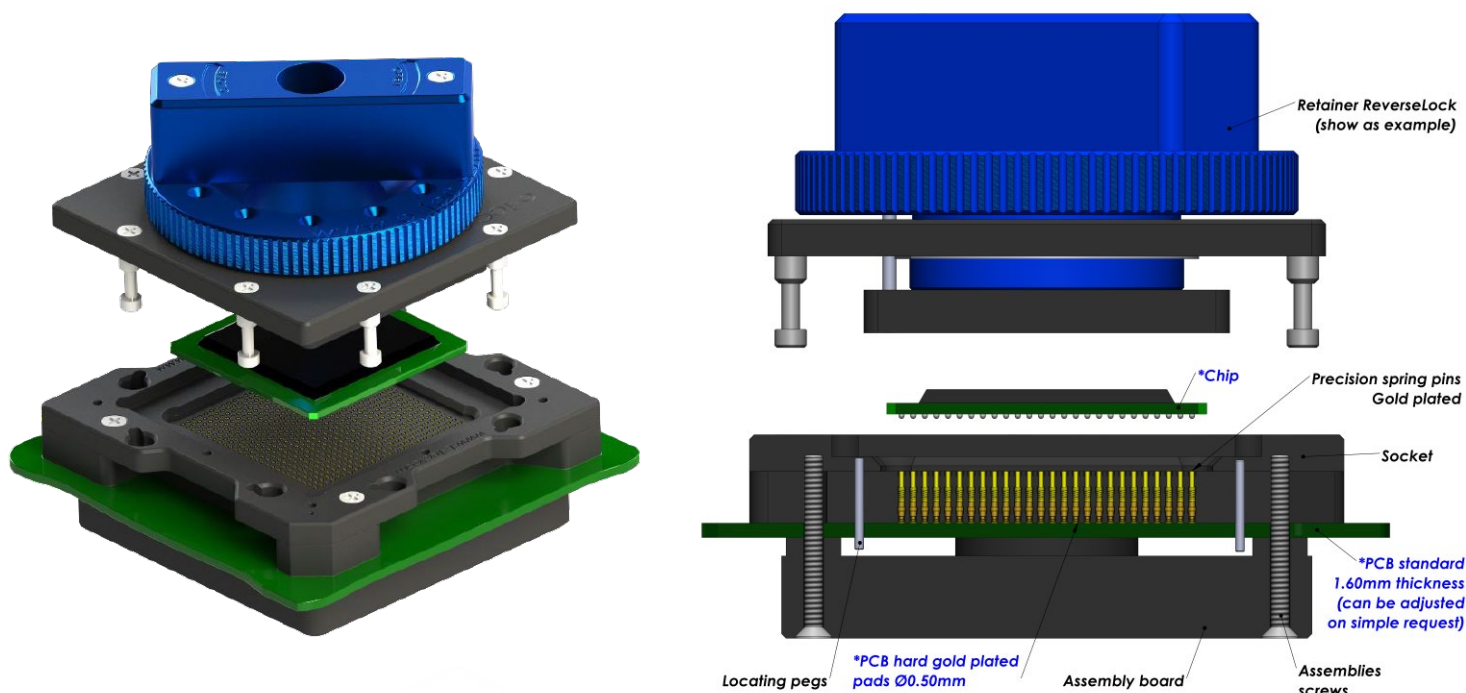
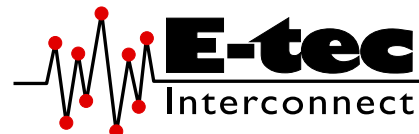

**E-tec Interconnect AG is the world leading Test socket manufacturer**

Probe Pin (Pogo) Solderless compression Test Sockets type are available for any chip size and pitch and are attached with 2, 4 or 8 screws to the PCB. The assembly board ensures perfect coplanarity of the socket. Contact reliability is guaranteed with spring loaded gold plated contacts, which are pressed onto gold plated PCB pads. Probe Pin (Pogo) Solderless compression type sockets are available with all retention systems. We aim to solve your requirements. Please note, we will always request the chip data to ensure we offer a compatible socket.

Contacts Specifications						
Contact type code	0890	0891	0893	0892	0894	0898
Application	Standard	High Frequency	Low Contact Resistance	High Frequency	Frequency	Frequency
Mounting	Solderless	Solderless	Solderless	Solderless	Solderless	Solderless
Bandwidth (GHz@-1dB)	3.4 GHz	36 GHz	7 GHz	31 GHz	14 GHz	31.7 GHz
Contact resistance	<100 mOhm	100 mOhm	40 mOhm	90 mOhm	90 mOhm	25 mOhm
Chip contact tip shape	Single Point tip Concave tip	Single Point tip	Crown tip	Single Point tip	Single Point tip	Single Point tip
PCB tip shape	Single Point tip	Single Point tip	Single Point tip	Spring	Spring	Spring
Force	30 gr	33 gr	23 gr	20 gr	20 gr	25 gr
Current rating	1.8 A	1 A	1 A	0.5 A	0.5 A	2.6 A
Capacitance pF	<1 pF	0.47 pF	0.55 pF	0.37 pF	0.30 pF	0.60 pF
Inductance nH	<2 nH	0.93 nH	1.08 nH	1.67 nH	1.66 nH	1.38 nH
Impedance Ohms	40 Ω	38 Ω	39 Ω	73 Ω	78 Ω	44.8 Ω
Temperature range	-55°C to +150°C	-40°C to +120°C	-50°C to +150°C	-55°C to +150°C	-55°C to +150°C	-55°C to +150°C
Mating cycles	100 K	100 K	100 K	100 K	100 K	100 K

More on the next page

