

Elastomer Solderless Compression Test Socket

For BGA / Bumped chip / WLCSP / eMMC Package

0.80 mm pitch (from 0.80 mm to 0.99 mm)

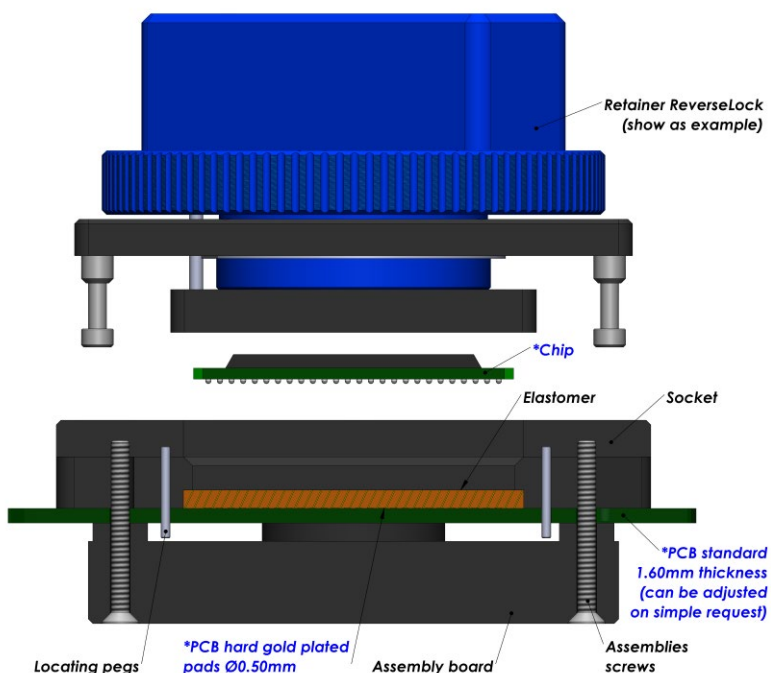
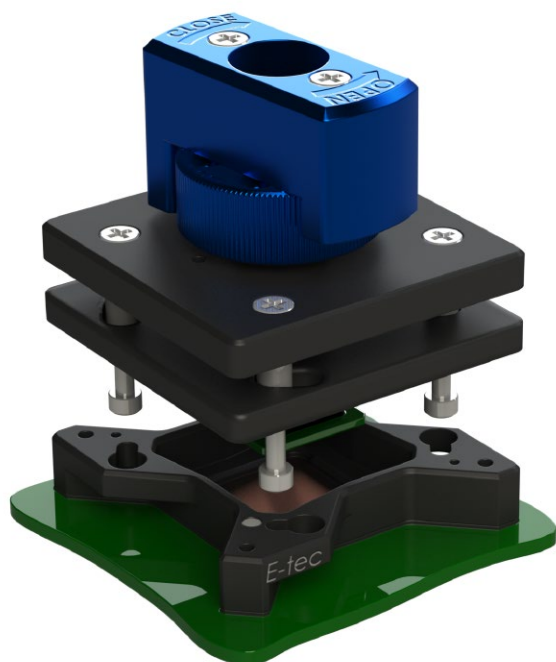
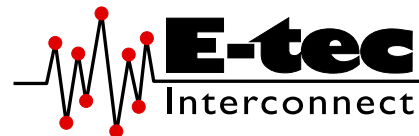

E-tec Interconnect AG is the world leading Test socket manufacturer

The Elastomer Solderless compression Test Sockets are ideal technical solution for good signal integrity with low signal loss. The sockets are available for any chip size and pitch and are attached with 2, 4 or 8 screws to the PCB. The socket outline will be kept to a minimum and special clearances can be offered to avoid components on the PCB.

SMT and thru-hole adapter sockets are available in certain pitches (contact factory for availability first) with these elastomer interposers to allow using this high frequency interposer on PCB's which have already been laid out for SMT or thru-hole sockets. We aim to solve your requirements. Please note, we will always request the chip data to ensure we offer a compatible socket.

Contacts Specifications		
Contact type code	E1	E2
Application	High Frequency	
Mounting	Solderless	Solderless
Bandwidth (GHz@-1dB)	23 GHz	24 GHz
Contact resistance	30 mOhm	
Chip contact tip shape	Gold Wire	
PCB tip shape	Gold Wire	
Force	20 gr to 50 gr	
Current rating	3 A	
Capacitance pF	0.26 pF	0.16 pF
Inductance nH	0.52 nH	0.26 nH
Impedance Ohms	44.8 Ω	44.4 Ω
Temperature range	-40°C to +125°C	
Mating cycles	1 K	

More on the next page

