

**Raised SMT soldering Test Socket**  
 For BGA / Bumped chip / WLCSP / eMMC Package  
**1.27 mm pitch** (from 1.27 mm upwards)

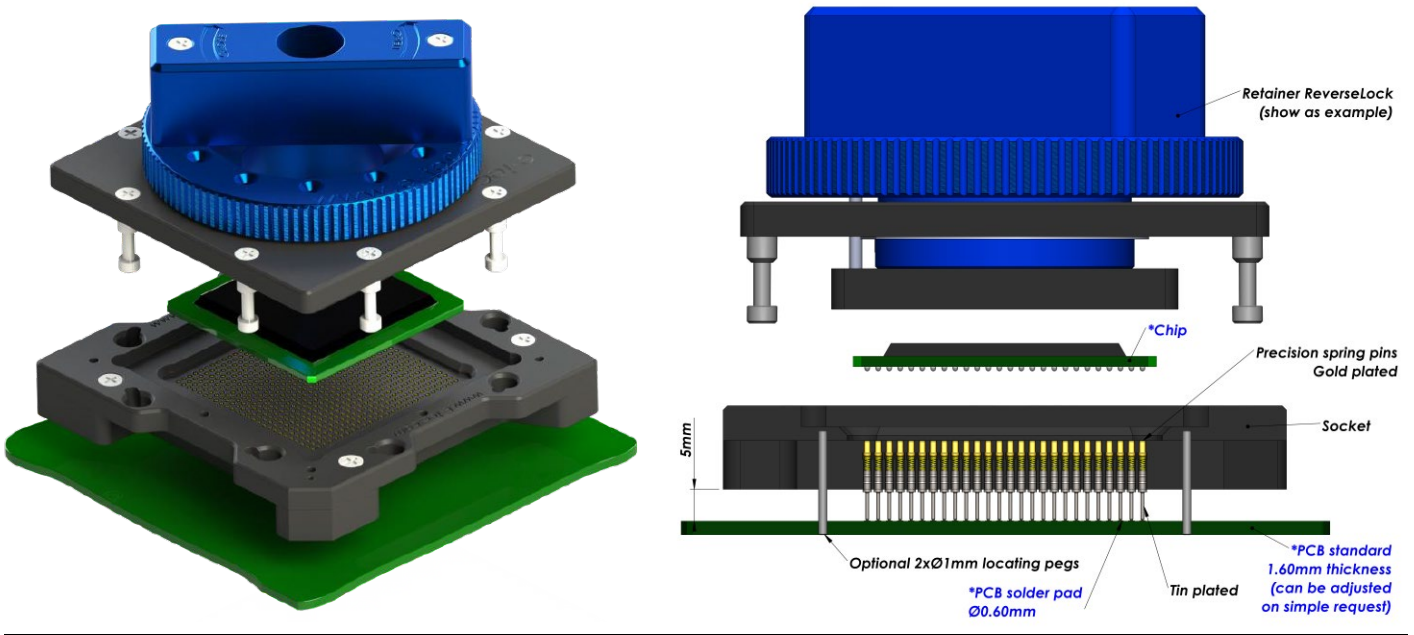
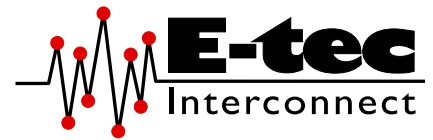

**E-tec Interconnect AG is the world leading Test socket manufacturer**

The Raised SMT socket lifts the socket above close-by components on PCB and uses the same footprint as your chip. Socket is simply placed and reflowed onto the PCB in the same way as the chip and it only requires a small amount of additional board space. Raised SMT sockets are available with all retention systems. We aim to solve your requirements. Please note, we will always request the chip data to ensure we offer a compatible socket. For Raised SMT sockets in general, E-tec Interconnect AG recommends the use of locating pegs, which can be soldered to the PCB for added mechanical strength.

Specifications contact type code 1229			
Application	Surface mouting	Force	25 gr
Mounting	Raised SMT	Current rating	2.2 A
Bandwidth (GHz@-1dB)	na	Capacitance pF	na
Contact resistance	<100mOhm	Inductance nH	na
Chip contact tip shape	Single Point tip or Concave tip	Temperature range	-55°C to +150°C
PCB tip shape	Raised SMT	Mating cycles	100 K

**How to order**

**BU # #### -1229 - ##### 95A #**

<p><b>Shape of tip</b></p> <p>U : Concave</p> <p><b>Options:</b></p> <p>P : Pointed</p> <p>S : Spring</p> <p>C : Crown</p>	<p><b>Nbr of contacts</b></p> <p>Depends on ballcount of chip</p>	<p><b>Contact type</b></p> <p>29 : Raised SMT – Dimension A = 5.00 mm</p>	<p><b>Plating</b></p> <p>95A: Tin/Gold + Alignment plate</p> <p>Other on request</p>	<p><b>Option code</b> (see page 16-19)</p> <p>D : Dead bug</p> <p>M : Multi frames</p> <p>U : Multi packages</p> <p>S : Custom opening slot</p> <p>L : Locating pegs</p> <p>H : Heatsink</p> <p>F : Fan + Heatsink</p> <p>P : Thermal drain pad</p> <p>W : Transparent lid</p> <p>I : Steel retention lid</p> <p>B : Aluminium retention lid</p> <p>T : Torque tool fixture</p> <p>G : Handling button</p>
<p><b>Retention frame type (Lid)</b> (see page 12-15)</p> <p>W: TwistLock</p> <p>F : FastLock</p> <p>B : SpringLock</p> <p>H : Open Clamshell Alu (&lt;200 contacts)</p> <p>J : Clamshell Alu (&gt;200 contacts)</p> <p>L : Open Lever Clamshell Alu (&gt;200 contacts)</p>		<p>S : ScrewLock</p> <p>Q : Open QuickLock (&lt;200 contacts)</p> <p>D : QuickLock (&gt;200 contacts)</p> <p>M : Injection Molded ClamShell</p> <p>R : ReverseLock</p> <p>T : SlimLock</p>		<p><b>Grid code / Config. code</b></p> <p>Will be given by the factory after receipt of the chip datasheet</p>

